

BACKPROPAGATION ARTIFICIAL NEURAL NETWORK FOR CLASSIFICATION ARRHYTHMIA IN ECG SIGNALS

Nurista Wahyu Kirana¹, Ervin Masita Dewi², Vanesha Putri Anggita³, Yana Sudarsa⁴, Dodi Budiman Margana⁵, Sugondo Hadiyoso^{6*}

Department of Electrical Engineering, Bandung State Polytechnic, Bandung, Indonesia^{1,2,3,4,5}

School of Applied Science, Telkom University, Bandung, Indonesia⁶

nurista.wahyu@polban.ac.id, ervinmasita@polban.ac.id, vanesha.putri.tele21@polban.ac.id,

yana.sudarsa@polban.ac.id, dodibudiman@polban.ac.id, sugondo@telkomuniversity.ac.id^{*}

Received: 18 June 2025, Revised: 12 April 2026, Accepted: 22 April 2026

**Corresponding Author*

ABSTRACT

Cardiovascular diseases (CVDs) remain the leading cause of mortality globally, accounting for approximately 17.9 million deaths annually. Among these, arrhythmias represent a significant concern due to their potential to lead to severe cardiac events. Traditional methods for detecting arrhythmias often require specialized equipment and healthcare facilities, which may not be readily accessible, especially in remote areas. This paper proposes the development of a portable electrocardiogram (ECG) device integrated with an Artificial Neural Network (ANN) using the Backpropagation algorithm to classify arrhythmias, thereby facilitating early detection and management. Arrhythmia is a heart condition characterized by an irregular heartbeat, where the heart may beat faster or slower than normal. Classification of arrhythmia can assist patients in monitoring their heart condition without needing to visit the hospital. This final project implements the Artificial Neural Network (ANN) method due to its ability to perform fast and accurate classifications. Prior to classification, feature extraction is carried out to detect the R wave interval, T wave interval, and the differences between the R and T wave intervals. The classification results are then displayed through a graphical user interface (GUI). The development of this ANN-based arrhythmia signal classification tool aims to help patients detect heart abnormalities at an early stage, potentially preventing the condition from worsening. Testing was conducted on 11 individuals, with 9 identified as having normal heart signals and 2 diagnosed with arrhythmia. When compared to a simulator, the classification system achieved 100% accuracy.

Keywords : *Arrhythmia, Artificial Neural Network, Backpropagation, Feature Extraction*

1. Introduction

Cardiovascular disease (CVD) remains the leading cause of mortality and disability worldwide, with approximately 19.2 million deaths and 437 million disability-adjusted life years (DALYs) in 2023, and the number of people living with CVD more than doubling since 1990 due to population aging, growth, and increasing exposure to modifiable risk factors such as hypertension, poor diet, and air pollution (Ahmed & Zhu, 2020). Despite rapid advancements in diagnostic imaging, catheterization technologies, and AI-enhanced decision support systems in high-income countries (HICs), low- and middle-income countries (LMICs) face significant limitations in access to these technologies because of inadequate infrastructure, workforce shortages, and underinvestment, which contribute to disparities in CVD outcomes (Ogungbe et al., 2024) (Akalm et al., 2025). For example, comprehensive electrophysiology and arrhythmia care including device implants and specialist training is underprovided in many LMICs, where at least one critical component of arrhythmia management (infrastructure, equipment, or expert personnel) is often lacking, resulting in higher mortality rates and treatment gaps. Meanwhile, digital health technologies such as telehealth, remote monitoring, and patient portals offer opportunities to expand access and improve outcomes; however, unequal access to broadband internet, digital devices, and digital literacy commonly referred to as the digital divide limits their impact in underserved regions (Nair et al., 2025) (Kazemi Lichae et al., 2023). Furthermore, cutting-edge machine learning (ML) and artificial intelligence (AI) models have the potential to enhance CVD risk stratification and early detection beyond traditional methods, but their implementation is hindered by uneven electronic health record data quality, validation challenges,

and interoperability barriers, particularly in resource-limited settings (Laurent, 2024) (Keva et al., 2024)

Among Cardiovascular diseases (CVDs), arrhythmias characterized by irregular heartbeats, pose significant health risks, potentially leading to severe complications such as heart failure or stroke. Early detection and management of arrhythmias are crucial; however, traditional diagnostic methods often require specialized equipment and trained personnel, which may not be readily accessible, particularly in remote or underserved regions.

Electrocardiography (ECG) is a fundamental tool for diagnosing arrhythmias, yet conventional ECG devices are often bulky and costly, limiting their widespread use. This limitation underscores the need for innovative solutions that enable timely and accurate detection of arrhythmias outside traditional healthcare settings.

This study proposes the development of a portable ECG device integrated with an Artificial Neural Network (ANN) utilizing the Backpropagation algorithm for arrhythmia classification. ANNs have demonstrated efficacy in ECG signal classification, with studies reporting high accuracy rates. For instance, a compact neural network algorithm achieved an accuracy of 97.36% in classifying arrhythmias using the MIT-BIH Arrhythmia Database.

The proposed system aims to provide a cost-effective and accessible solution for early arrhythmia detection, enabling individuals to monitor their heart health independently. By leveraging portable technology and advanced machine learning algorithms, this approach seeks to bridge the gap between healthcare access and the need for timely cardiac care (Xiaolin et al., 2023).

2. Literature Review

Cardiovascular diseases, particularly arrhythmias, are leading causes of mortality worldwide. Early detection is crucial for effective management and prevention of severe complications. Recent advancements in signal processing and artificial intelligence have facilitated the development of systems capable of classifying normal and abnormal cardiac signals.

(Kirana & Dewi, 2024) (Masita Dewi et al., 2025) project Arterial Stiffness Analysis for Cardiovascular Disease Detection Using Integrated Biosensor, contributes to this field by exploring how integrated biosensor systems can measure arterial stiffness for CVD detection. (Fauzi et al., 2023) put forth a methodology for implementing k-fold cross-validation in conjunction with neural network techniques, taking into account varying k values and the appropriate types of distance metrics. The empirical findings indicated that the optimal accuracy of 98.2% was achieved when k was set to 1, utilizing the cosine distance metric within the framework of a five-fold cross-validation evaluation model. (Chen et al., 2022) utilized Artificial Neural Networks (ANNs) to detect cardiovascular disease. ANN architecture based on a one-dimensional convolutional neural network and a short- and long-term memory network, which can directly classify unsegmented signals to identify abnormal signals. The results show that the ANN model provides good overall balanced accuracy of 0.86 ± 0.01 with a sensitivity of 0.87 ± 0.02 and a specificity of 0.89 ± 0.02 . (Deng et al., 2020) focused on classifying normal heartbeats using heart sound recordings. By employing Mel Frequency Cepstral Coefficients (MFCC) for feature extraction and ANN for classification, they achieved classification accuracy of 98%, respectively, demonstrating the applicability of ANN in heart sound analysis. (Rema & Maheswaran, 2023) developed an intelligent system for detecting normal and abnormal heart signals using ANN. ANN are utilized for the segmentation of input electrocardiogram (ECG) images. The proposed methodology employs the Fourier transform to eliminate the inherent noise of ECG signals during the preprocessing phase, thereby facilitating the accurate categorization of ECG samples into primary arrhythmia classifications. This illustrates the efficacy of the proposed ECG classification model in accurately identifying ECG signals for abnormality detection in conjunction with an Internet of Things (IoT) framework. Several studies have applied ANN to classify heart disease using a model that simulates the human brain's neural network. Their study achieved an accuracy of 73.77%, with precision, recall, and F1-score values of 80.43%, 84.09%, and 82.22%, respectively, underscoring the potential of ANN in medical diagnostics (Vu et al., 2023) (Katal et al., 2023).

The reviewed studies demonstrate the efficacy of ANN in classifying normal and abnormal cardiac signals, whether from ECG or heart sound recordings (Marinucci et al., 2020). These advancements pave the way for developing portable and accessible diagnostic tools, particularly beneficial in remote areas with limited healthcare facilities (Ansari et al., 2023)(Cai et al., 2021)

Based on a critical review of the related literature, various machine learning and deep learning approaches, including SVM, CNN, and ANN, have been widely applied for ECG signal classification with satisfactory performance. Several studies indicate that backpropagation-based ANN demonstrates stable and reliable performance in ECG classification, particularly under limited data conditions, while maintaining lower computational complexity. Therefore, ANN is selected in this study as a method that provides a balanced trade-off between accuracy and efficiency. The novelty of this research lies in the application of ANN using primary ECG data for validation, which remains limited in prior studies that predominantly rely on secondary datasets, thereby addressing an existing research gap and enhancing the validity of the results under real-world conditions(Cheng et al., 2025).

2.1 Electrocardiogram (ECG)

An electrocardiogram is a diagnostic test that records the heart's electrical activity using electrodes placed on the body. It is commonly used to assess heart function, though a normal ECG does not always rule out heart problems. ECG Components are waves, segments, and Intervals.

1. Waves

P Wave: Represents atrial depolarization (from the SA node to the AV node). A normal P wave has a duration of ≤ 0.12 seconds and amplitude ≤ 3 mm (0.3 mV). Abnormal duration or height may indicate left or right atrial enlargement.

Q Wave: The initial negative deflection in the QRS complex, indicating early ventricular depolarization.

R Wave: The first positive deflection in the QRS complex, representing ventricular depolarization.

S Wave: The negative deflection following the R wave.

QRS Complex: Represents depolarization of both the left and right ventricles.

T Wave: Indicates ventricular repolarization, usually showing a slow upward slope followed by a steeper downward slope.

2. Segments

PR Segment: Between the end of the P wave and the start of the QRS complex.

ST Segment: Between the end of the QRS complex and the start of the T wave.

TP Segment: Between the end of the T wave and the start of the next P wave.

3. Intervals

PR Interval: From the beginning of the P wave to the start of the QRS complex.

QT Interval: From the start of the QRS complex to the end of the T wave.

RR Interval: The time between two successive R waves. Normally ranges from 0.6 to 1.2 second(Anbalagan et al., 2023). The intervals are crucial for diagnosing arrhythmias and assessing overall heart rhythm stability.

ECG Interval Calculation to determine the intervals between specific waves in an ECG signal, the following equations are used. R Interval calculates the interval between two successive R waves, T Interval calculates the interval between two successive T waves, which can be useful for analyzing ventricular repolarization timing, and RT Interval Difference calculates the time difference between the previous R wave and the previous T wave, which can help analyze the spacing and coordination between ventricular depolarization and repolarization (Sannino & De Pietro, 2018)(Wu et al., 2021).

$$R \text{ Interval} = R_2 - R_1 \quad (1)$$

$$T \text{ Interval} = T_2 - T_1 \quad (2)$$

$$RT \text{ Interval Difference} = R_1 - T_1 \quad (3)$$

R₁: The value (time) of the previous R peak
 R₂: The value (time) of the current R peak
 T₁: The value (time) of the previous T peak
 T₂: The value (time) of the current T peak

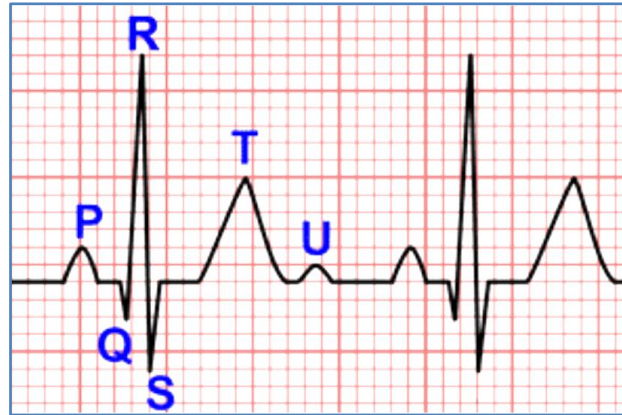

Fig. 1. ECG waves and segments

2.2 Artificial Neural Network (ANN)

An Artificial Neural Network is a learning model inspired by the human brain, which learns from examples or training data. Similar to biological neurons consisting of dendrites, soma, and axons, ANN is composed of artificial neurons connected by weights and biases. The network typically consists of three main layers. Input Layer which connects the network to the data source and passes the input forward to the next layer. Hidden Layer then processes the input data, adjusting internal parameters to reduce error and improve output accuracy. The last is Output Layer that produces the final result of the network's computation (Ullah et al., 2020). Each neuron in the input and hidden layers is connected by weights (V for input-to-hidden, W for hidden-to-output), and optionally includes biases to enhance learning speed. The hidden layer value can be calculated using the formula in equation 4 (Talukder et al., 2025).

$$X_1 = (In_1 \times W_1) + (In_2 \times W_2) + B_1 \quad (4)$$

X_1 = Hidden layer output

In_1/In_2 = Inputs

W_1/W_2 = Weights

B_1 = Bias

2.3 Backpropagation Algorithm

Backpropagation is a learning algorithm used in ANN training with two main phases, Forward Propagation that computes the output based on current weights and biases and Backward Propagation that adjusts the weights (V and W) to minimize the error between the actual and target outputs. Backpropagation uses training and testing phases. During training, it performs both forward and backward propagation to optimize the weights. In the testing phase, only forward propagation is executed. The formulas are in equation 5 and 6 (Ogundepo & Ponnle, 2015) (Jin et al., 2024)

$$V = (n_{input} + 1) \times n_{hidden} \quad (5)$$

$$W = (n_{hidden} + 1) \times n_{output} \quad (6)$$

Weight V (Input to Hidden)

Weight W (Hidden to Output)

n_{input} = Number of neurons in the input layer

n_{hidden} = Number of neurons in the hidden layer

n_{output} = Number of neurons in the output layer

In backpropagation, several key parameters play a crucial role in determining the effectiveness of the training process. The number of iterations refers to how many times the neural network goes through the training dataset, essentially defining the total training cycles. Error tolerance sets the threshold for how close the predicted output needs to be to the actual target; a smaller error tolerance generally means the model is performing more accurately. Lastly, the learning rate dictates the speed at which the model adjusts its weights during training too high a rate may cause the model to overshoot optimal values, while too low a rate can lead to slow convergence (Montenegro et al., 2022) (Panwar et al., 2025).

3. Research Methods

The research begins with the acquisition of raw ECG signals, which are obtained from various sources such as an ECG simulator, MIT-BIH arrhythmia database, or direct ECG signal measurements. These raw signals undergo data acquisition, where they are digitized and prepared for further analysis. Following this, feature extraction is performed to identify key characteristics from the ECG signals such as heart rate, QRS complex duration, and RR intervals which are essential for distinguishing between normal and abnormal heart patterns. Next, feature selection is applied to refine the extracted features, retaining only the most relevant data that significantly impact classification performance. These selected features constitute the training dataset, which is then used to train an Artificial Neural Network model. The ANN learns from the patterns in the data to classify or predict cardiac conditions. Finally, the trained model is evaluated to determine the predicted accuracy, which reflects the effectiveness of the entire ECG signal processing and classification (Botros et al., 2022)

The ANN-BP method uses ECG datasets from three sources: an ECG simulator, the MIT-BIH Arrhythmia Database, and direct ECG signal measurements. The dataset consists of two classes Normal (target 0) and Arrhythmia (target 1) and is divided into 82% training data (51 data) and 18% testing data (11 data). Signals with different durations are also used to evaluate model consistency.

Feature extraction is performed to obtain relevant ECG characteristics, which are arranged in a horizontal format and used as ANN inputs. The ANN architecture is a feedforward network with an input layer, one or more hidden layers, and an output layer, implemented using the *nntool* in the Neural Network Toolbox.

The classification process involves training the network using backpropagation to obtain optimal weights, followed by testing with unseen data. The ANN outputs values close to the target (≈ 0 for normal and ≈ 1 for arrhythmia), demonstrating accurate and effective ECG signal classification.

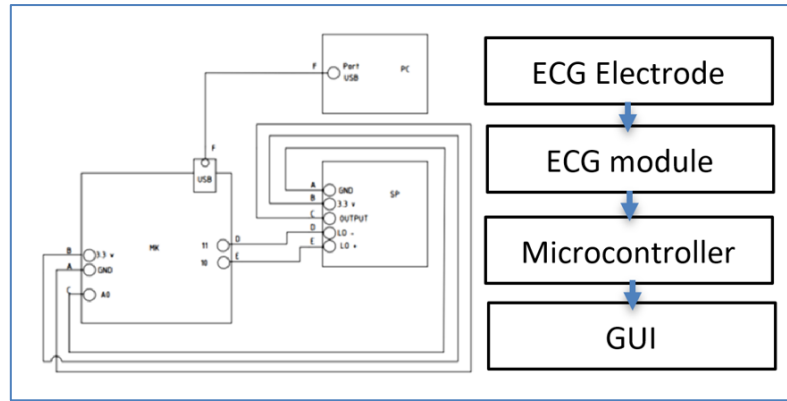

Fig. 2. Propose research methods

The 3-lead ECG system is a basic configuration commonly used for continuous cardiac monitoring, such as in emergency rooms, intensive care units (ICUs) (Chattopadhyay, 2022) or during surgical procedures. It consists of three electrodes: one positive, one negative, and one ground as reference. The typical placement on the body can be seen in table 1.

Table 1. 3-lead ECG typical placement

Electrode	Cable Color
RA (Right Arm)	Red
LA (Left Arm)	Yellow
LL (Left Leg)	Green

Electrocardiogram signals are recorded from patients using electrodes placed on the surface of the skin. The classification process begins with data acquisition. Data acquisition involves collecting signals from a module, which are then processed by a microcontroller. These signals can be used to analyze and identify whether a patient has a normal or abnormal heart condition. The data is collected over a period of two minutes (Xiao et al., 2023)(Fiorina et al., 2024)

Preprocessing consists of several steps, including filtering and normalization. A Finite Impulse Response (FIR) filter is applied to remove noise from the signal. Normalization is then used to simplify data processing and improve signal interpretation Figure 3. Feature extraction is the stage where the signal is processed to identify its unique characteristics, enabling the differentiation between normal and arrhythmic ECG signals (Mondal et al., 2024). In this step, analysis focuses on the differences between arrhythmic and normal signals. In arrhythmic signals, the R and T intervals, as well as the difference between them, deviate from normal values. These deviations are used as features for classification.

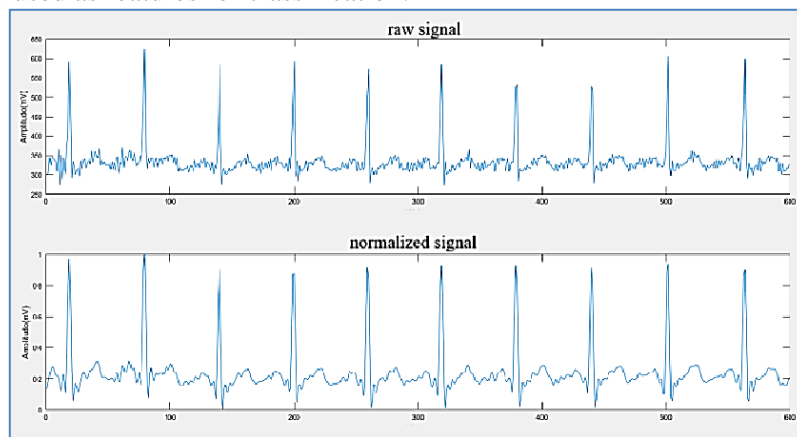

Fig. 3. Raw and normalized signal

Testing of the R-R interval is performed to determine whether each R interval falls within the normal range. A normal R interval typically ranges between 0.6 seconds and 1 second. Figure 4 shows the program used for R-peak interval testing.

T interval analysis is performed to determine the duration of each T interval and to calculate the difference between the R and T intervals. The program used for this analysis is illustrated in Figure 5. The variation between the R and T intervals is a key indicator for distinguishing normal heart rhythms from arrhythmias. The formula used in this analysis is shown in Equation 3. Based on the program's output, normal heartbeats typically exhibit a difference of less than 20 milliseconds, whereas arrhythmic signals tend to show inconsistent or abnormal values. Figure 6 displays the results of the R-T interval difference analysis.

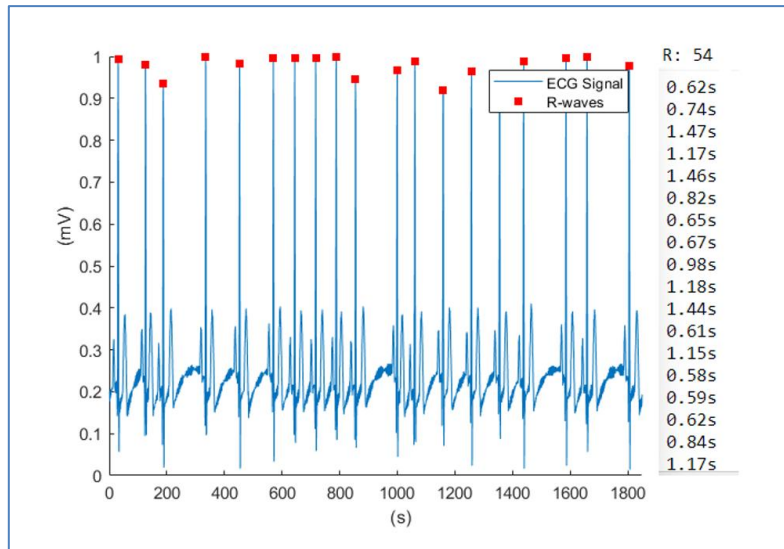

Fig. 4. R-peak interval

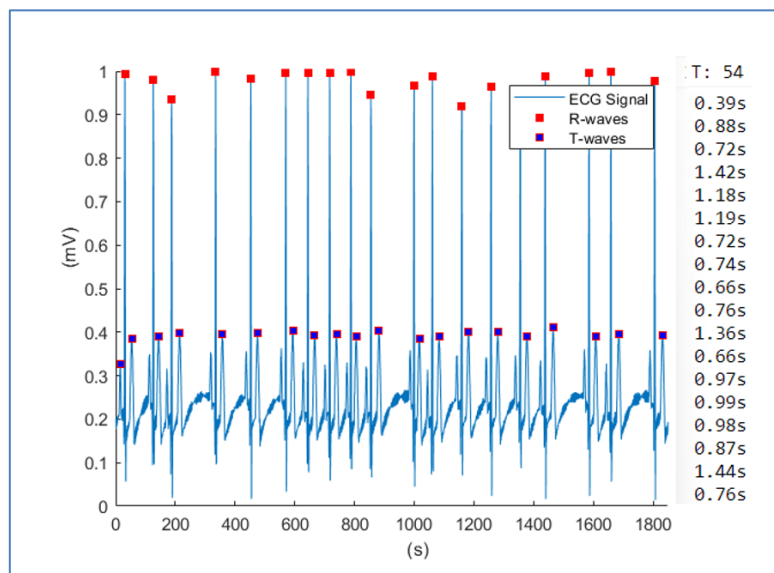

Fig. 5. T-peak interval

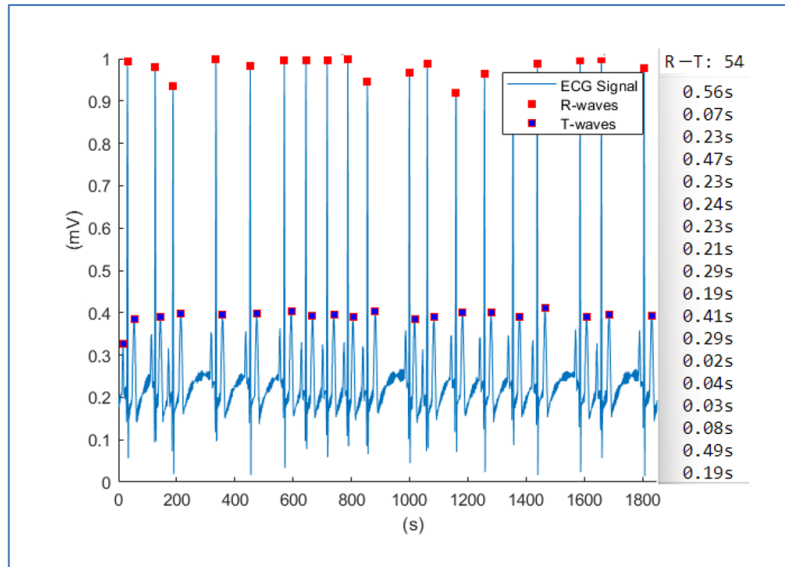

Fig. 6. R-T interval difference

The classification process utilizes the ANN-BP (Artificial Neural Network - Backpropagation) method. In this step, classification is achieved by comparing the test data against the training data. The training data acts as a reference to help the ANN-BP learn and identify ECG signal patterns. This dataset is sourced from previously recorded signals. Vice versa, the test data is collected in real-time from respondents and serves as the input for classification. Once processed, the classification results are displayed through a GUI.

During this process, the ANN algorithm analyzes the test data by comparing it to the training patterns. If the result aligns with a known pattern from the training data, the patient is classified as having arrhythmia. If it does not match, the patient is considered not to have arrhythmia. The classification outcome is visualized on the GUI, as shown in Figure 7.

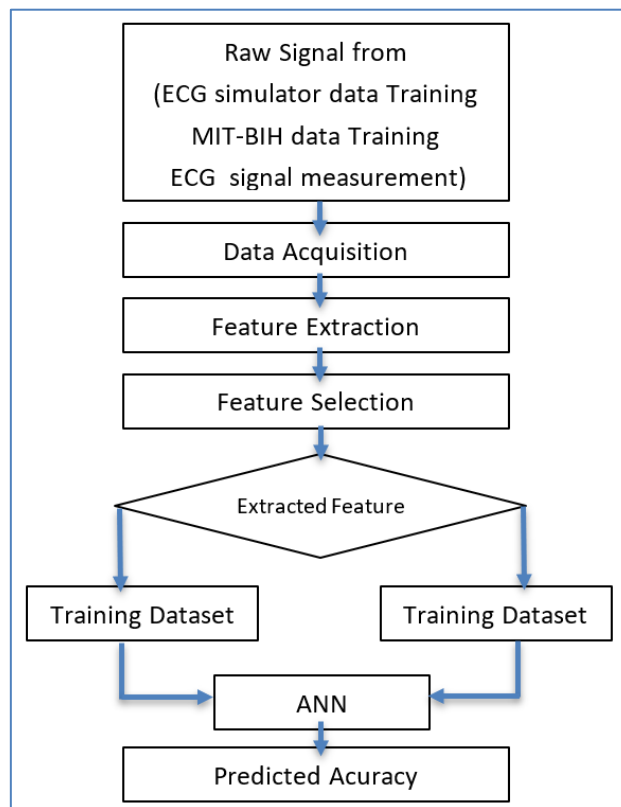

Fig. 7. ANN backpropagation process

In the implementation of an ANN, both training data and test data are required to train the network. The network learns from the training data in order to classify specific problems. Training data consists of inputs along with their corresponding target outputs.

The first step in the classification process is feature extraction, the results of which are used as input for the test data. The input data must be arranged in a horizontal format rather than vertical to ensure the signal displays correctly. If the data is initially vertical, it should be transposed to a horizontal format. Once the input and target data are prepared, the next step is to use the GUI tool called nntool, which is part of the Neural Network Toolbox in the GUI environment.

The nntool is used to train the neural network. Input data includes both the training data and the test data obtained from earlier processing. The target data, derived from the training set, helps determine the output typically either a 1 or 0. The network section in the tool defines the structure of the neural network used for training.

For training, 70% of the available data is used, while the remaining 30% is reserved for testing. A larger portion of training data helps the model better learn patterns and features, while the test data ensures accurate and reliable performance evaluation. The test data is input into the system to evaluate whether the ANN-BP output matches the expected target. If the result aligns with the target, the ANN-BP model is considered effective. Table 2 shows the training data of the ANN-BP model.

Table 2 - Training Data

No.	Interval R (s)	Interval T (s)	Difference (s)	Target
1	0.73	0.74	0.01	0
2	1.47	0.78	0.69	1

Target Key:

0 = Normal heartbeat

1 = Arrhythmia

4. Results and Discussions

Based on Figure 8 and 9, the interface of the developed GUI includes several key features designed to facilitate ECG signal processing and classification. The Start button initiates real-time data acquisition, displaying the signal on axes1, labeled as the real-time panel. This process runs for two minutes to collect data for further analysis. The Save button allows users to store the captured data from the Arduino into an Excel file and automatically converts it into a .mat file, enabling direct loading without the need for manual file conversion. The Load File button is used to display previously saved non-real-time data on axes2, located under the feature extraction display panel.

The Feature Extraction button processes the recorded signal to extract relevant characteristics, including the R interval, T interval, and the difference between them. These extracted values are then converted into a format suitable for GUI input and serve as data for classification. The ANN button activates the nntool function, which contains the training data and classification model. The extracted features are input into the simulation to be evaluated against the learning data, with the simulation output indicating whether arrhythmia is present. Finally, the Classification button processes the ANN output, which is in binary form (1 or 0). If the mode of the output is 1, the patient is classified as having arrhythmia, if the mode is 0, the patient is considered normal. The final classification result is displayed in static text2 within the GUI.

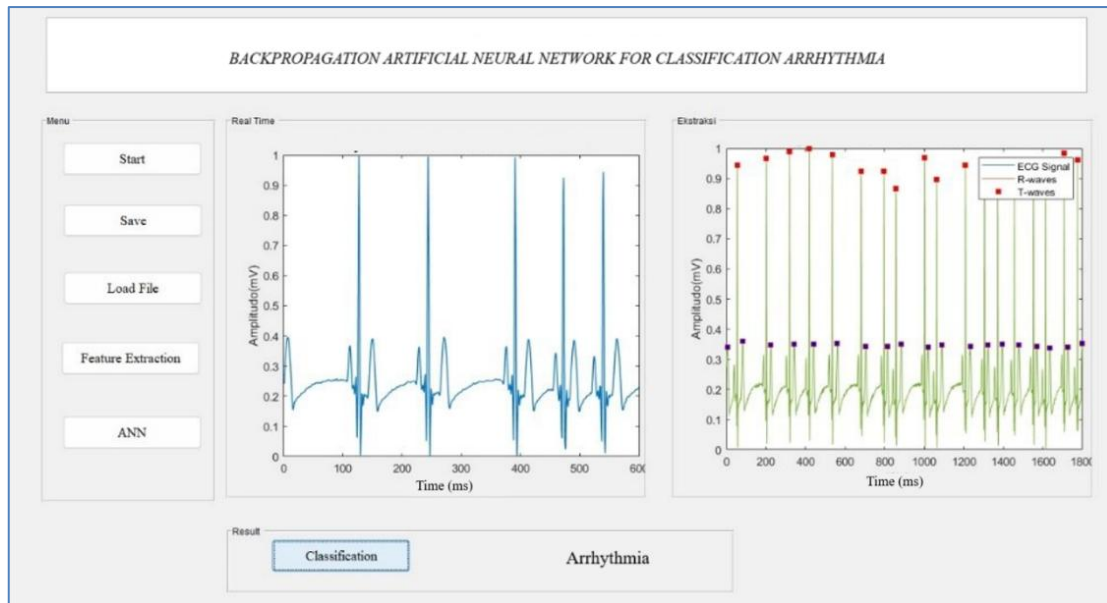

Fig. 8. Interface of the developed GUI with arrhythmia classification

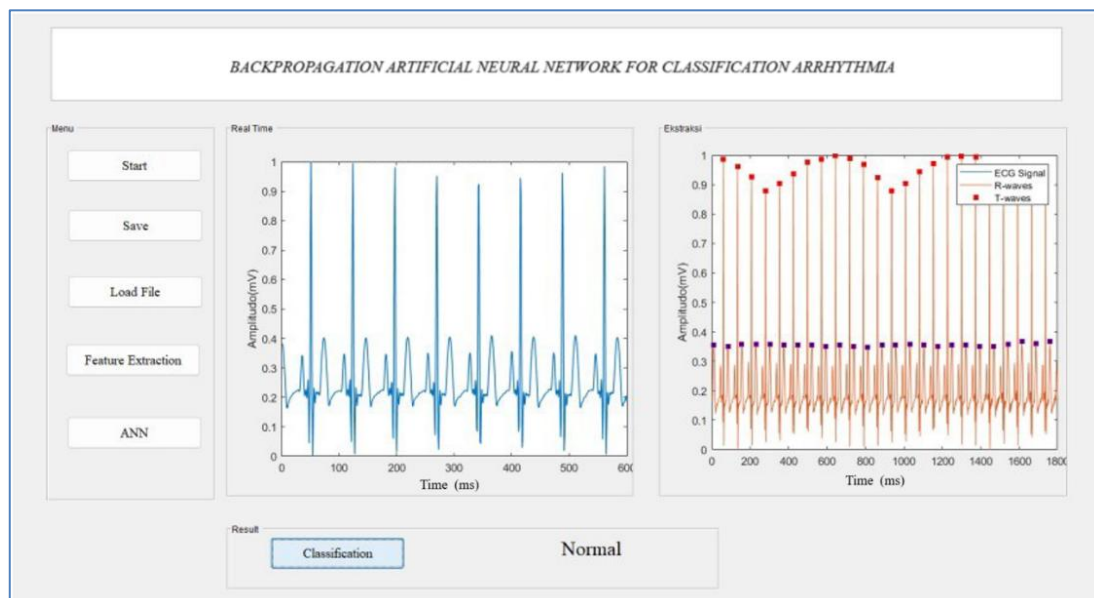

Fig. 9. Interface of the developed GUI with normal classification

Table 3. ANN-BP testing results

No.	Target	ANN Output	Description
1	0	0.03	Matches Target
2	1	0.96	Matches Target

The ANN-BP testing results used ECG simulator, MIT-BIH arrhythmia database, and direct ECG signal measurements. These signals served as both training and testing data, using the same model as outlined in Table 2. The results showed that the model was able to accurately classify the signals according to the target. According to Table 3, the ANN-BP test conducted on signals with different durations but using the same model as the training data also demonstrated that the model could successfully classify the signals as expected. For Normal (Target 0): ANN

output ≈ 0 (0.03 \rightarrow classified as normal). For Arrhythmia (Target 1): ANN output ≈ 1 (0.96 \rightarrow classified as arrhythmia). Accuracy: 100% match between targets and predictions. The Figure 10 is a picture of the confusion matrix.

		Predicted	
		Positive	Negative
Actual	Positive	2	0
	Negative	0	9

Fig. 10. Confusion Matrix

The application of advanced neural network models for ECG signal classification offers substantial benefits for clinical practice and real diagnostic application workflows. By enabling rapid identification of abnormal cardiac rhythms, such systems can significantly shorten the time required for diagnosis and support timely clinical decision making, particularly in high throughput clinical environments and emergency settings. In addition, automated classification enhances diagnostic consistency by applying standardized criteria across all cases, thereby reducing inter-observer variability commonly encountered in manual ECG interpretation.

High confidence predictions generated by these models allow effective triage of clinical workloads, enabling cardiologists and medical technicians to concentrate on complex or high risk cases that require expert attention. When integrated with wearable and remote monitoring technologies, neural network based ECG analysis facilitates continuous and homebased monitoring of cardiac conditions such as atrial fibrillation. This continuous surveillance capability increases the likelihood of early detection of potentially life threatening arrhythmias, which may help prevent adverse events including stroke or sudden cardiac arrest that are often missed by intermittent testing.

Furthermore, automated ECG analysis systems function as a reliable secondary review tool by highlighting suspicious patterns and providing quantitative performance indicators, such as classification probabilities, sensitivity, and specificity. These objective metrics complement conventional ECG interpretation and contribute to greater diagnostic confidence. Owing to their advanced feature extraction capabilities, deep learning models are also able to identify subtle or rare abnormalities and to discriminate accurately among diverse arrhythmia types, supporting more precise patient profiling and individualized treatment planning.

Beyond individual patient care, the deployment of neural network based ECG classification has broader implications for healthcare systems. Such technologies can improve access to expert level diagnostics, reduce clinician workload, and support longitudinal follow up without the need for frequent hospital visits. These advantages are particularly relevant in telemedicine applications and in regions with limited access to specialized cardiology services. By extending classification capabilities to clinically significant conditions such as atrial fibrillation and ventricular tachycardia, these systems enable more accurate risk stratification and inform targeted preventive and therapeutic strategies, thereby contributing to improved outcomes in cardiovascular care.

5. Conclusion

This study has successfully implemented a backpropagation-based Artificial Neural Network for the classification of arrhythmia in ECG signals. The proposed model demonstrates the feasibility of applying supervised neural network learning to accurately identify cardiac rhythm patterns from ECG data. The proposed model employed in this study consists of three input layers, four hidden layers, and one output layer. The training process was conducted over

1,000 iterations, where the predefined number of iterations determined the stopping criterion of the system. Based on the experimental results, the proposed model achieved an accuracy of 100% in classifying ECG signals according to their respective arrhythmia classes, indicating a strong capability of the network in learning the underlying signal patterns. Despite the promising results obtained, further improvements can be explored in future work. These include the incorporation of additional or more advanced feature extraction techniques to enhance the model's ability to represent and process ECG signals more effectively. Moreover, extending the classification framework to accommodate a wider range of arrhythmia types would improve the robustness and clinical relevance of the system. In addition, validation using a larger and more diverse dataset is necessary to assess the robustness, generalizability, and reliability of the proposed method

Acknowledgement

This work was supported by the DIPA Politeknik Negeri Bandung No.109.8/R7/PE.01.03/2025.

References

- Ahmed, N., & Zhu, Y. (2020). Early Detection of Atrial Fibrillation Based on ECG Signals. *Bioengineering*, 7(1). <https://doi.org/10.3390/bioengineering7010016>
- Akalın, F., Çavdaroglu, P. D., & Orhan, M. F. (2025). Arrhythmia detection with transfer learning architecture integrating the developed optimization algorithm and regularization method. *BMC Biomedical Engineering*, 7(1), 8. <https://doi.org/10.1186/s42490-025-00094-4>
- Anbalagan, T., Nath, M. K., Vijayalakshmi, D., & Anbalagan, A. (2023). Analysis of various techniques for ECG signal in healthcare, past, present, and future. *Biomedical Engineering Advances*, 6, 100089. <https://doi.org/https://doi.org/10.1016/j.bea.2023.100089>
- Ansari, Y., Mourad, O., Qaraq, K., & Serpedin, E. (2023). Deep learning for ECG Arrhythmia detection and classification: an overview of progress for period 2017–2023. *Frontiers in Physiology*, Volume 14-2023. <https://doi.org/10.3389/fphys.2023.1246746>
- Botros, J., Mourad-Chehade, F., & Laplanche, D. (2022). CNN and SVM-Based Models for the Detection of Heart Failure Using Electrocardiogram Signals. *Sensors*, 22(23). <https://doi.org/10.3390/s22239190>
- Cai, J., Zhou, G., Dong, M., Hu, X., Liu, G., & Ni, W. (2021). Real-Time Arrhythmia Classification Algorithm Using Time-Domain ECG Feature Based on FFNN and CNN. *Mathematical Problems in Engineering*, 2021(1), 6648432. <https://doi.org/https://doi.org/10.1155/2021/6648432>
- Chattopadhyay, S. (2022). The Importance of Time-Domain HRV Analysis in Cardiac Health Prediction. *Series of Cardiology Research*, 4, 19–23. <https://doi.org/10.54178/2768-5985.2022a5>
- Chen, D., Xuan, W., Gu, Y., Liu, F., Chen, J., Xia, S., Jin, H., Dong, S., & Luo, J. (2022). Automatic Classification of Normal–Abnormal Heart Sounds Using Convolution Neural Network and Long-Short Term Memory. *Electronics*, 11(8). <https://doi.org/10.3390/electronics11081246>
- Cheng, Y., Wan, S., Luo, J., Zhu, C., & Xie, C. (2025). Design and Implementation of a Sleep Respiratory Continuous wearable Monitor Based on ECG Cardiopulmonary Coupling and Cloud-Edge Collaboration. *2025 IEEE 23rd International Conference on Industrial Informatics (INDIN)*, 1–9. <https://doi.org/10.1109/INDIN64977.2025.11279492>
- Deng, M., Meng, T., Cao, J., Wang, S., Zhang, J., & Fan, H. (2020). Heart sound classification based on improved MFCC features and convolutional recurrent neural networks. *Neural Networks*, 130, 22–32. <https://doi.org/https://doi.org/10.1016/j.neunet.2020.06.015>
- Fauzi, H., Rizal, A., 'Aqila, M., Oktariato, A., & Said, Z. (2023). Classification of Normal and Abnormal Heart Sounds Using Empirical Mode Decomposition and First Order Statistic. *Journal of Electronics, Electromedical Engineering, and Medical Informatics*, 5(2). <https://doi.org/10.35882/jeeemi.v5i2.287>
- Fiorina, L., Chemaly, P., Cellier, J., Said, M. A., Coquard, C., Younsi, S., Salerno, F., Horvilleur, J., Lacotte, J., Manenti, V., Plesse, A., Henry, C., & Lefebvre, B. (2024). Artificial

- intelligence-based electrocardiogram analysis improves atrial arrhythmia detection from a smartwatch electrocardiogram. *European Heart Journal - Digital Health*, 5(5), 535–541. <https://doi.org/10.1093/ehjdh/ztae047>
- Jin, Y., Li, Z., Wang, M., Liu, J., Tian, Y., Liu, Y., Wei, X., Zhao, L., & Liu, C. (2024). Cardiologist-level interpretable knowledge-fused deep neural network for automatic arrhythmia diagnosis. *Communications Medicine*, 4(1), 31. <https://doi.org/10.1038/s43856-024-00464-4>
- Katal, N., Gupta, S., Verma, P., & Sharma, B. (2023). Deep-Learning-Based Arrhythmia Detection Using ECG Signals: A Comparative Study and Performance Evaluation. *Diagnostics*, 13(24). <https://doi.org/10.3390/diagnostics13243605>
- Kazemi Lichae, F. K. L., Salari, A. S., Jalili, J. J., Beikmohammad Dalivand, S. B. D., Roshanfekar Rad, M. R. R., & Mojarad, M. M. (2023). Advancements in Artificial Intelligence for ECG Signal Analysis and Arrhythmia Detection: A Review. *International Journal of Cardiovascular Practice*, 8(2), e143437. <https://doi.org/10.5812/intjcardiovascpract-143437>
- Keva, G., Iltaf, S. D., Ritu, Y., Jeffrey, B., O, A. C., O, M. O., A, C. L., A, N. M., Felix, S., S, B. G., R, J. L., & David, S. (2024). Global Health Inequities in Electrophysiology Care. *JACC: Advances*, 3(12_Part_2), 101387. <https://doi.org/10.1016/j.jacadv.2024.101387>
- Kirana, N. W., & Dewi, E. M. (2024). Arterial Stiffness Analysis for Cardiovascular Disease Detection Using Integrated Biosensor. *2024 IEEE Technology & Engineering Management Conference - Asia Pacific (TEMSCON-ASPAC)*, 1–7. <https://doi.org/10.1109/TEMSCON-ASPAC62480.2024.11025062>
- Marinucci, D., Sbröllini, A., Marcantoni, I., Morettini, M., Swenne, C. A., & Burattini, L. (2020). Artificial Neural Network for Atrial Fibrillation Identification in Portable Devices. *Sensors*, 20(12). <https://doi.org/10.3390/s20123570>
- Masita Dewi, E., Wahyu Kirana, N., & Hadiyoso, S. (2025). Analyzing the impact of sports activity intensity on muscle capacity through integrated biosensor technology. *TELKOMNIKA (Telecommunication Computing Electronics and Control)*, 23(2), 466. <https://doi.org/10.12928/telkomnika.v23i2.26264>
- Mondal, A., Manikandan, M. S., & Pachori, R. B. (2024). ECG Quality Detection and Noise Classification for Wearable Cardiac Health Monitoring Devices. *2024 16th International Conference on Electronics, Computers and Artificial Intelligence (ECAI)*, 1–6. <https://doi.org/10.1109/ECAI61503.2024.10607491>
- Montenegro, L., Abreu, M., Fred, A., & Machado, J. M. (2022). Human-Assisted vs. Deep Learning Feature Extraction: An Evaluation of ECG Features Extraction Methods for Arrhythmia Classification Using Machine Learning. *Applied Sciences*, 12(15). <https://doi.org/10.3390/app12157404>
- Nair, P., Dai, M., Patel, D. A., Pearlman, K., & Shah, S. D. (2025). Equity by Design – Using Digital Technology To Overcome Cardiovascular Health Disparities. *Current Cardiology Reports*, 27(1), 157. <https://doi.org/10.1007/s11886-025-02319-3>
- Ogundepo, O., & Ponnle, A. (2015). Development of a Computer-Aided Application for Analyzing ECG Signals and Detection of Cardiac Arrhythmia Using Back Propagation Neural Network -Part II: GUI Development. *International Journal of Applied Information Systems*, 9, 29–36. <https://doi.org/10.5120/ijais15-451379>
- Ogungbe, O., Longenecker, C. T., Beaton, A., de Loizaga, S., Brant, L. C. C., Turkson Ocran, R. N., Bastani, P., Sarfo, F. S., & Commodore-Mensah, Y. (2024). Advancing Cardiovascular Health Equity Globally Through Digital Technologies. *Journal of the American Heart Association*, 13(2), e031237. <https://doi.org/10.1161/JAHA.123.031237>
- Panwar, A., Narendra, M., Arya, A., Raj, R., & Kumar, A. (2025). Integrated portable ECG monitoring system with CNN classification for early arrhythmia detection. *Frontiers in Digital Health, Volume 7-2025*. <https://doi.org/10.3389/fdgth.2025.1535335>
- Rema, K., & Maheswaran, C. P. (2023). Processing of ECG Signal Using Optimized Feature Selection for the Prediction of Irregular Heart Beat. *2023 International Conference on Circuit Power and Computing Technologies (ICCPCT)*, 1109–1114. <https://doi.org/10.1109/ICCPCT58313.2023.10245440>

- Sannino, G., & De Pietro, G. (2018). A deep learning approach for ECG-based heartbeat classification for arrhythmia detection. *Future Generation Computer Systems*, 86, 446–455. <https://doi.org/10.1016/j.future.2018.03.057>
- Talukder, Md. A., Talaat, A. S., Muna, N. J., Alazab, A., Kazi, M., & Das, U. K. (2025). An explainable deep learning framework for trustworthy arrhythmia detection from ECG signals. *Scientific Reports*, 15(1), 39496. <https://doi.org/10.1038/s41598-025-22986-0>
- Ullah, A., Anwar, S. M., Bilal, M., & Mehmood, R. M. (2020). Classification of Arrhythmia by Using Deep Learning with 2-D ECG Spectral Image Representation. *Remote Sensing*, 12(10). <https://doi.org/10.3390/rs12101685>
- Vu, T., Petty, T., Yakut, K., Usman, M., Xue, W., Haas, F. M., Hirsh, R. A., & Zhao, X. (2023). Real-time arrhythmia detection using convolutional neural networks. *Frontiers in Big Data*, Volume 6-2023. <https://doi.org/10.3389/fdata.2023.1270756>
- Wu, M., Lu, Y., Yang, W., & Wong, S. Y. (2021). A Study on Arrhythmia via ECG Signal Classification Using the Convolutional Neural Network. *Frontiers in Computational Neuroscience*, Volume 14-2020. <https://doi.org/10.3389/fncom.2020.564015>
- Xiao, Q., Lee, K., Mokhtar, S. A., Ismail, I., Pauzi, A. L. bin M., Zhang, Q., & Lim, P. Y. (2023). Deep Learning-Based ECG Arrhythmia Classification: A Systematic Review. *Applied Sciences*, 13(8). <https://doi.org/10.3390/app13084964>
- Xiaolin, L., Xiang, F., Panicker, R. C., Cardiff, B., & John, D. (2023). Classification of ECG based on Hybrid Features using CNNs for Wearable Applications. *2023 IEEE 5th International Conference on Artificial Intelligence Circuits and Systems (AICAS)*, 1–4. <https://doi.org/10.1109/AICAS57966.2023.10168568>