

## DEVELOPMENT OF POTATO-DERIVED CARBON NANOFIBERS AS SUSTAINABLE MOISTURE-REGULATING SUPPORTING LAYERS FOR PHOTOVOLTAIC MODULES

Indri Dayana<sup>1</sup>, Habib Satria<sup>2\*</sup>, Nidya Chitraningrum<sup>3</sup>, Mega Puspita Sari<sup>4</sup>, Tino Hermanto<sup>5</sup>, Yopan Rahmad Aldori<sup>6</sup>, Dadan Ramdan<sup>7</sup>, Syofyan Anwar Syahputra<sup>8</sup>, Dina Maizana<sup>9</sup>, Moranain Mungkin<sup>10</sup>, Junaidi<sup>11</sup>, Ade Irma Sagala<sup>12</sup>, Siti Utari Rahayu<sup>13</sup>

Engineering Faculty, Universitas Medan Area, Medan 20223, Sumatera Utara, Indonesia<sup>1,2,4,5,6,7,9,10</sup>

Research Centre for Biomass and Bioproduct, National Research and Innovation Agency, BRIN, Bogor 16911, Indonesia<sup>3</sup>

Research Collaboration Centre for Carbon Materials-based Biomass for Conversion and Energy Storage, Universitas Riau and Research and Innovation Agency, Riau, Indonesia<sup>3</sup>

Akademi Teknik Deli Serdang<sup>3,8</sup>

Mechanical Engineering Faculty, Universitas Harapan, Medan 20216, Sumatera Utara, Indonesia<sup>11</sup>

Belawan Maritim Academy, Medan 20124, Sumatera Utara, Indonesia<sup>12</sup>

Department of Physics and Institute of Nanoscience, National Chung Hsing University, Taichung, 402, Taiwan<sup>13</sup>

habib.satria@staff.uma.ac.id<sup>2\*</sup>

Received: 18 October 2025, Revised: 08 April 2026, Accepted: 12 April 2026

\*Corresponding Author

### ABSTRACT

Moisture-induced degradation remains a critical reliability issue in photovoltaic (PV) modules, particularly in humid tropical climates. While biomass-derived carbon materials have been widely investigated for electrochemical applications, their use as functional supporting layers in PV modules remains limited. This study develops potato-derived carbon nanofibers through moderate-temperature carbonization (700 °C, N<sub>2</sub> atmosphere) followed by electrospinning. Structural and chemical properties were evaluated using XRD, FTIR, Raman spectroscopy, and BET surface area analysis. Morphology and fiber diameter distribution were examined via SEM. Electrical conductivity was measured using a four-point probe method. Water vapor permeability (WVP) and biodegradation behavior were assessed to evaluate durability and moisture regulation capability. The synthesized material exhibits predominantly amorphous turbostratic carbon with characteristic D and G Raman bands (ID/IG ≈ 0.92), specific surface area of 186 ± 12 m<sup>2</sup>/g, and electrical conductivity of 3.8 ± 0.4 S/m. Nanofiber diameters range from 72–108 nm (mean ± SD). Controlled WVP (3200–4100 mg/day/L) and moderate biodegradability (8–12% mass loss over 14 days) indicate balanced vapor diffusion and structural integrity. The results demonstrate the feasibility of potato-derived carbon nanofibers as sustainable moisture-regulating supporting layers in photovoltaic modules.

**Keywords** : Biomass Carbon, Electrospinning, Raman Spectroscopy, BET Surface Area, Electrical Conductivity, Photovoltaic Durability

### 1. Introduction

The rapid global expansion of photovoltaic (PV) technology has significantly contributed to the transition toward sustainable energy systems. Despite substantial improvements in photovoltaic conversion efficiency, long-term operational stability remains a major challenge, particularly in tropical and humid environments (Satria et al., 2025). Moisture ingress is widely recognized as one of the most critical factors responsible for photovoltaic module degradation. The penetration of water vapor into multilayer PV structures can accelerate corrosion of metallic contacts, induce encapsulant deterioration, promote delamination, and reduce overall electrical performance (Dayana et al., 2025).

In recent years, increasing attention has been directed toward developing sustainable materials capable of improving photovoltaic durability while simultaneously reducing environmental impacts. Conventional polymer-based supporting layers frequently exhibit limited moisture management capability, leading to localized condensation and interfacial degradation during long-term operation (Yi et al., 2026). Therefore, advanced porous materials with controlled vapor permeability have emerged as promising candidates for moisture regulation within photovoltaic systems (Supha et al., 2026).

Biomass-derived carbon materials have attracted significant interest due to their renewable nature, low production cost, environmental compatibility, and tunable physicochemical properties (Sohail, 2025). Agricultural residues, lignocellulosic biomass, starch-rich feedstocks, and food-processing wastes have been successfully converted into porous carbon structures for applications in energy storage, catalysis, environmental remediation, sensors, and advanced functional materials (Yeamsuksawat et al., 2023). The ability to tailor pore structure, surface chemistry, electrical conductivity, and mechanical properties through carbonization processes has further expanded the potential applications of biomass-derived carbons (Singh et al., 2023). Among various biomass resources, potatoes represent a particularly attractive carbon precursor because of their high starch content, relatively homogeneous composition, low ash concentration, and favorable carbonization behavior (Jeong et al., 2024). Previous investigations have demonstrated that potato-derived carbon materials can achieve significant porosity and electrical conductivity suitable for supercapacitors, batteries, and microbial fuel cells. However, most reported studies have primarily focused on electrochemical energy-storage applications, while the utilization of potato-derived carbon materials for photovoltaic durability enhancement remains largely unexplored (Dayana et al., 2024).

Electrospinning technology provides a versatile approach for fabricating continuous nanofiber networks with controllable morphology, high surface area, interconnected pore structures, and excellent structural flexibility (Fachredzy et al., 2026). Electrospun carbon nanofibers possess unique characteristics that can facilitate controlled moisture transport while maintaining structural integrity. These properties make them attractive candidates for multifunctional supporting layers in photovoltaic modules where moisture regulation and mechanical stability are simultaneously required (Lopes et al., 2026). Although biomass-derived carbon nanomaterials have been extensively investigated, several research gaps remain. First, studies exploring potato-derived carbon nanofibers as functional supporting layers for photovoltaic modules are extremely limited. Second, the moisture-regulating functionality of carbon nanofiber structures has not been systematically evaluated for photovoltaic applications. Third, most reported biomass-derived carbons require high-temperature carbonization and chemical activation, which increase energy consumption and environmental burden (Idris et al., 2026).

Therefore, this study aims to develop potato-derived carbon nanofibers through moderate-temperature carbonization and electrospinning techniques and evaluate their structural, morphological, surface, electrical, and moisture-regulation properties. The novelty of this work lies in repositioning potato-derived carbon nanofibers from conventional electrochemical applications toward sustainable moisture-regulating supporting layers for photovoltaic modules. The findings provide new insights into the multifunctional utilization of biomass-derived carbon nanostructures for renewable energy systems.

## 2. Literature Review

### Biomass-Derived Carbon Materials

Biomass-derived carbon materials have emerged as a major class of sustainable engineering materials due to their abundance, renewability, and low environmental impact (Beissenov et al., 2024). Carbon materials produced from agricultural biomass generally exhibit hierarchical pore structures, tunable surface chemistry, and moderate electrical conductivity. Such characteristics have enabled their application in supercapacitors, batteries, catalysts, adsorbents, sensors, and environmental remediation technologies (Straten et al., 2025).

Recent developments in biomass valorization have demonstrated that carbon materials derived from food-processing waste can achieve physicochemical properties comparable to those

obtained from conventional synthetic precursors. The use of biomass resources further supports circular-economy strategies by converting agricultural waste into value-added functional materials (Medina-Jaramillo et al., 2025).

### **Potato-Derived Carbon Materials**

Potatoes contain substantial amounts of starch, cellulose, hemicellulose, and carbon-rich organic compounds suitable for carbon-material production. Previous studies have reported the successful synthesis of porous carbons from potato peels and potato waste through carbonization and activation processes (William et al., 2022). These materials have shown promising performance in electrochemical energy-storage applications due to their high surface area and favorable pore distribution.

However, most reported investigations emphasize capacitance enhancement, charge-storage mechanisms, and electrode performance. The structural utilization of potato-derived carbon materials for photovoltaic applications remains largely unexplored (Kuc et al., 2024).

### **Electrospun Carbon Nanofibers**

Electrospinning is a widely utilized nanofabrication technique capable of producing continuous fibers with diameters ranging from several nanometers to micrometers. Carbon nanofibers fabricated through electrospinning exhibit interconnected porous structures, high aspect ratios, controllable morphology, and mechanical flexibility (Zhang et al., 2023).

The porous architecture generated through electrospinning can facilitate vapor transport and moisture regulation while maintaining structural stability. These properties make electrospun carbon nanofibers attractive for advanced engineering applications requiring multifunctional performance (Phuong et al., 2025).

### **Moisture Management in Photovoltaic Modules**

Moisture accumulation is one of the primary causes of photovoltaic deffydation. Water penetration into module structures can initiate corrosion of conductive pathways, deterioration of encapsulation materials, and loss of interfacial adhesion. Consequently, moisture-management strategies are increasingly recognized as critical components of photovoltaic reliability engineering.

Materials exhibiting controlled water-vapor permeability can potentially reduce moisture accumulation by promoting gradual vapor diffusion and minimizing condensation formation. The integration of porous carbon nanofiber layers may therefore provide an effective approach for improving photovoltaic durability in humid operating environments (Dayana et al., 2025).

### **Research Gap and Novelty**

Although extensive studies have been conducted on biomass-derived carbons for electrochemical applications, the use of potato-derived electrospun carbon nanofibers as moisture-regulating supporting layers for photovoltaic modules has not been comprehensively investigated. Furthermore, limited information is available regarding the relationship between nanofiber morphology, vapor permeability, electrical conductivity, and photovoltaic durability (Dayana et al., 2024).

The present work addresses these gaps by synthesizing potato-derived carbon nanofibers through a sustainable moderate-temperature carbonization route and evaluating their suitability as multifunctional supporting materials for photovoltaic systems.

## **3. Materials and Methods**

### **Biomass Preparation**

The materials used in this study were potatoes obtained from Deli Serdang, North Sumatra, Indonesia. All chemicals used were obtained from Sigma, Germany (Dayana et al., 2025). Potatoes were washed, sliced, oven-dried (105 °C, 24 h), milled with disk mill machine (<100 µm), and used without chemical pretreatment (Dayana et al., 2024; Medina-Jaramillo et al., 2025).

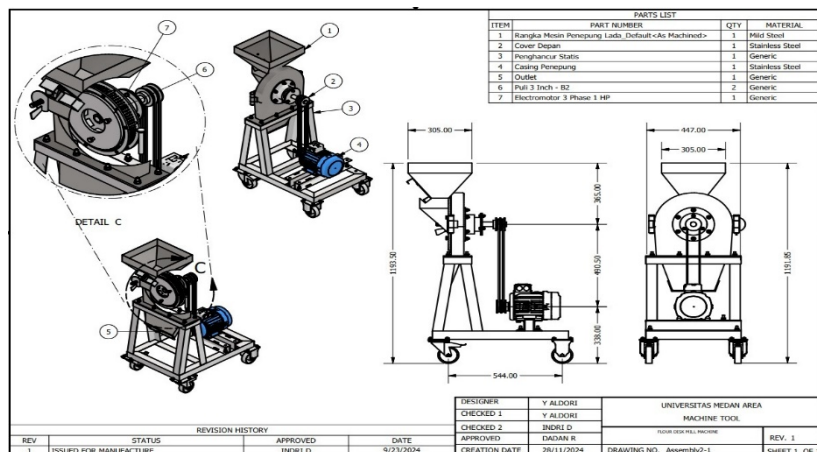

Fig. 1. Disk Mill Machine Design

### Carbonization

Carbonization was conducted at 700 °C for 2 h under nitrogen atmosphere (heating rate 5 °C/min). The inert atmosphere prevents oxidation and promotes development of carbon framework(Fachredzy et al., 2026).

### Electrospinning

Carbonized powder was dispersed in a solvent mixture (acetic acid, lactic acid, trifluoroacetic acid)(Straten et al., 2025). Electrospinning parameters:Voltage: 20 kV, Flow rate: 0.5 mL/h, Needle-collector distance: 15 cm, Collector rotation speed: 500 rpm, Ambient temperature: 25 ± 2 °C, Relative humidity: 45 ± 5%(Petrichenko et al., 2024). Experiments performed in triplicate(Alfei & Zuccari, 2025).



Fig. 2. Electrospinning process

### Characterization Techniques

XRD (10–80° 2θ), FTIR (400–4000 cm<sup>-1</sup>), Raman spectroscopy (532 nm excitation laser), BET surface area analysis (N<sub>2</sub> adsorption-desorption at 77 K), SEM (10 kV), Electrical conductivity (four-point probe method), Fiber diameters measured using ImageJ (n ≥ 100 fibers/sample)(Jeong et al., 2024; Ali et al., 2022).

### Water Vapor Permeability

Measured using gravimetric cup method (ASTM E96 adapted)(Dayana et al., 2025). Values expressed as mean ± SD(Dayana et al., 2021),(Kumar et al., 2022).

### Biodegradation Test

Mass loss (%) = [(m<sub>0</sub> - m<sub>t</sub>) / m<sub>0</sub>] × 100. Testing duration: 14 days under controlled humidity(Hoffmann et al., 2020; Singh & Biswas, 2025).

## 4. Results and Discussion

### XRD Analysis

The X-ray diffraction (XRD) patterns of potato-derived carbon nanofibers are presented in Figure 3. Broad diffraction peaks centered at approximately  $24^\circ$  and  $43^\circ$  correspond to the (002) and (100) crystallographic planes of turbostratic carbon, respectively. The broad nature of these reflections indicates a predominantly amorphous carbon structure with limited graphitic ordering (Dayana et al., 2025).

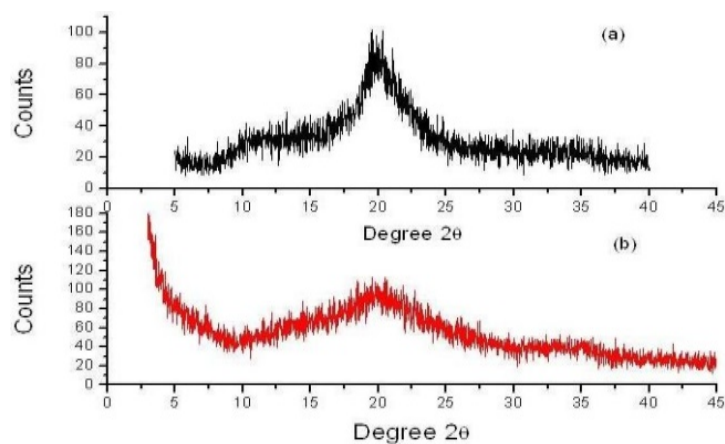

Fig 3. The XRD analysis of two potatoes pure and potatoes- mixed

The formation of turbostratic carbon is commonly observed in biomass-derived carbon materials synthesized at moderate carbonization temperatures ( $600\text{--}800^\circ\text{C}$ ). At this temperature range, partial aromatization occurs while complete graphitization remains limited (Guirguis et al., 2023). Similar structural characteristics have been reported for potato-derived porous carbons, lignin-derived carbon nanofibers, and cellulose-based carbon materials (Lopes et al., 2026). The presence of disordered graphitic domains is advantageous for moisture-regulating applications because it provides structural stability while preserving sufficient porosity for vapor transport.

The expanded interlayer spacing associated with turbostratic carbon may further facilitate moisture diffusion through the carbon network. Unlike highly graphitized carbons, which generally exhibit dense structures and reduced permeability, the partially ordered carbon framework obtained in this study offers a balanced combination of mechanical integrity and vapor-transmission capability. This structural feature is particularly beneficial for photovoltaic supporting layers where moisture regulation rather than maximum electrical conductivity is the primary objective (HEMMAMI et al., 2024).

### Raman Spectroscopy

Raman spectra reveal two characteristic bands located near  $1350\text{ cm}^{-1}$  (D-band) and  $1580\text{ cm}^{-1}$  (G-band), confirming the successful formation of carbonaceous nanostructures (Xi et al., 2026). The D-band originates from structural defects and disordered carbon domains, whereas the G-band is associated with graphitic  $\text{sp}^2$  carbon networks.

The measured ID/IG ratio of approximately 0.92 indicates a partially graphitized carbon structure with moderate defect density (Al-jamimi et al., 2026). This value is consistent with many biomass-derived carbon nanofibers produced through moderate-temperature carbonization. The observed defect concentration plays an important role in regulating both moisture transport and surface interactions.

A moderate level of structural disorder can increase the number of active adsorption sites available for water molecules. Consequently, moisture can be temporarily adsorbed and gradually released through interconnected pore channels. This mechanism is advantageous for photovoltaic modules operating in humid environments because sudden moisture accumulation may be minimized.

Furthermore, partially graphitized domains contribute to electrical conductivity while maintaining structural flexibility. The coexistence of graphitic and amorphous regions therefore generates multifunctional behavior involving vapor diffusion, charge dissipation, and mechanical support. Similar observations have been reported for electrospun biomass-derived carbon nanofibers utilized in advanced energy applications(Honcharuk et al., 2024).

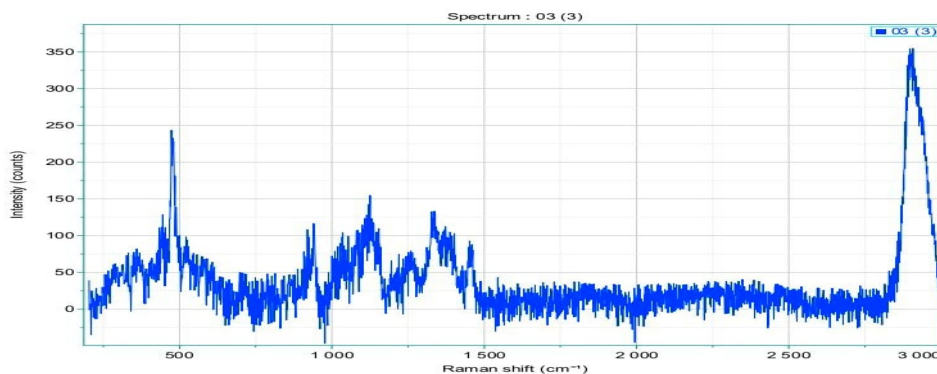

Fig 4. The Raman analysis of potatoes- mixed

### BET Surface Area and Porosity

Nitrogen adsorption-desorption measurements indicate a specific surface area of  $186 \pm 12$  m<sup>2</sup>/g with a total pore volume of  $0.21 \pm 0.03$  cm<sup>3</sup>/g(Zhang et al., 2023). The adsorption isotherm exhibits Type IV behavior accompanied by an H3 hysteresis loop, confirming the predominance of mesoporous structures.

Compared with activated carbons designed for supercapacitors, the measured surface area is relatively moderate(Zhong et al., 2022). However, for moisture-regulating photovoltaic applications, extremely high surface areas are not necessarily desirable. Excessive porosity may reduce mechanical strength and accelerate structural degradation under long-term environmental exposure(Straten et al., 2025).

The moderate surface area obtained in this study provides sufficient adsorption sites for moisture regulation while preserving structural integrity(Dayana et al., 2025). Mesopores facilitate vapor diffusion through the nanofiber network, whereas smaller pores contribute to temporary moisture retention. Such hierarchical pore structures enable gradual moisture equilibration rather than rapid condensation accumulation. Recent studies have emphasized that electrospun biomass-derived nanofibers benefit from interconnected mesoporous networks because they simultaneously promote transport phenomena and maintain mechanical robustness. The BET results therefore support the proposed functionality of the material as a moisture-regulating support layer within photovoltaic module architectures(Gamage et al., 2022).

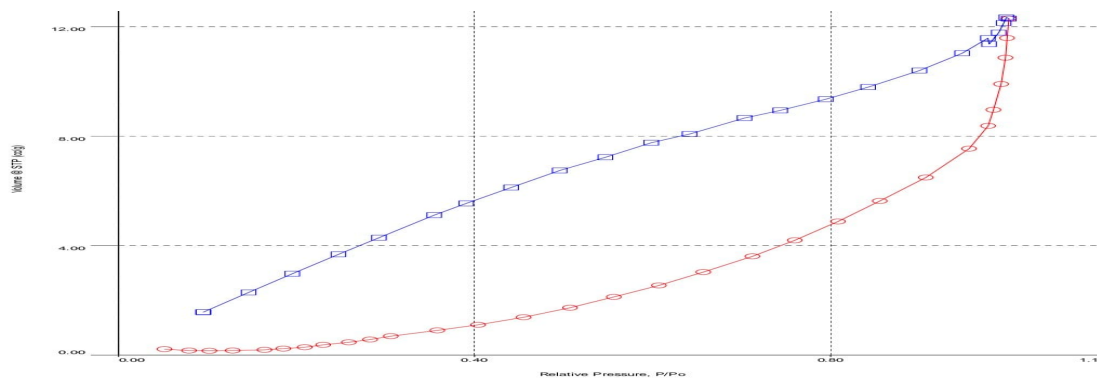

Fig. 5. BET Surface Area and Porosity potatoes- mixed

### FTIR Analysis

The FTIR spectra reveal broad O–H stretching vibrations around  $3400\text{ cm}^{-1}$ , aromatic C=C vibrations near  $1600\text{ cm}^{-1}$ , and C–O stretching bands within the  $1050\text{--}1200\text{ cm}^{-1}$  region (Dayana et al., 2025). These functional groups indicate the presence of residual oxygen-containing surface functionalities after carbonization.

The reduction in hydroxyl-group intensity compared with raw potato biomass confirms dehydration and aromatization during thermal treatment. Nevertheless, the remaining oxygen-containing functional groups contribute positively to moisture-regulation performance. Surface oxygen functionalities can interact with water molecules through hydrogen bonding, thereby enhancing moisture adsorption and controlled desorption behavior (Yeamsuksawat et al., 2023). The coexistence of aromatic carbon structures and residual oxygen groups generates a balanced hydrophilic-hydrophobic surface character (Yi et al., 2026). This balance is important because completely hydrophobic materials exhibit limited moisture interaction, whereas excessively hydrophilic materials may retain excessive moisture and compromise durability.

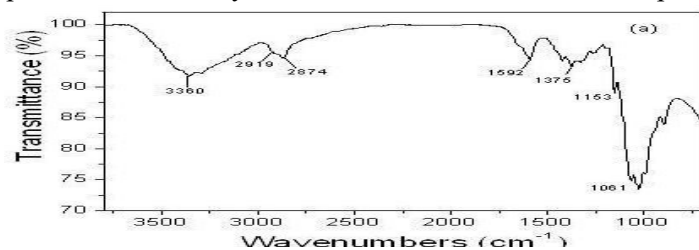

Fig 6. Fourier transform infrared (FT-IR) spectra of pure potatoes

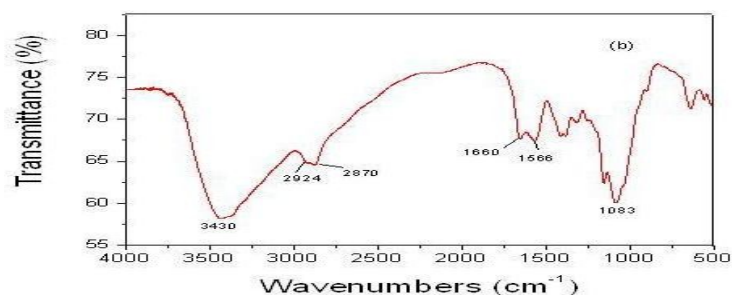

Fig. 7. Fourier transform infrared (FT-IR) spectra of potatoes-mixed

### SEM Morphology

SEM micrographs reveal continuous interconnected nanofiber networks with relatively uniform diameter distributions. Average fiber diameters of  $72.4 \pm 11.6\text{ nm}$  and  $108.3 \pm 15.2\text{ nm}$  were obtained for the investigated systems (Dayana et al., 2025).

The formation of nanoscale fiber networks is particularly beneficial for vapor transport. Small fiber diameters increase the surface-area-to-volume ratio, thereby enhancing interactions between water vapor and the carbon surface. Simultaneously, interconnected pores formed between neighboring fibers create continuous diffusion pathways throughout the material.

Previous studies have demonstrated that electrospun carbon nanofibers possessing diameters below  $200\text{ nm}$  generally exhibit enhanced transport properties due to shortened diffusion distances. The diameter range observed in this work falls within the optimal region for balancing permeability and structural stability (Dayana et al., 2021).

Moreover, the absence of significant bead formation indicates stable electrospinning conditions and effective precursor dispersion. Uniform morphology contributes to consistent vapor permeability across the material, which is desirable for photovoltaic moisture-management applications.

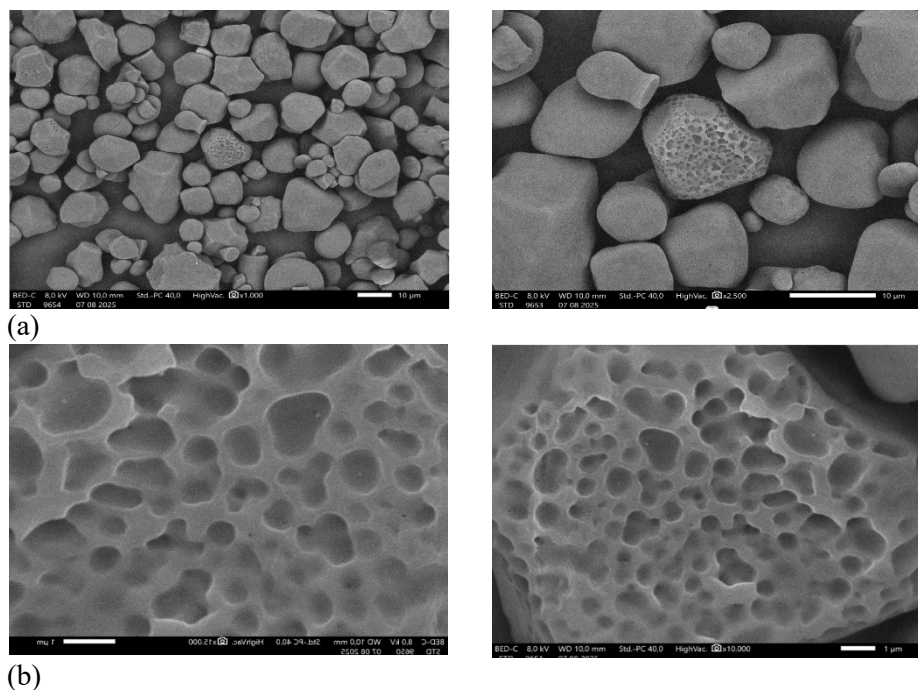

Fig. 8. The SEM analysis and the magnetite particles distribution for two different samples (pure potatoes (a) and potatoes- mixed (b))

### Electrical Conductivity

Electrical conductivity measurements yielded values of approximately  $3.8 \pm 0.4$  S/m. Although lower than highly graphitized carbon electrodes, this conductivity level is adequate for auxiliary electrical functions within photovoltaic module structures (William et al., 2022).

The observed conductivity originates from partially graphitized carbon domains identified by Raman and XRD analyses. Conductive pathways distributed throughout the nanofiber network may facilitate dissipation of localized electrostatic charges and reduce charge accumulation at material interfaces.

For photovoltaic supporting layers, the primary function is not energy generation or storage but rather structural support combined with environmental protection. Therefore, moderate conductivity is advantageous because it provides electrical functionality without requiring energy-intensive graphitization processes (Aseel et al., 2022).

### Water Vapor Permeability

Water vapor permeability values ranged from  $3200 \pm 150$  to  $4100 \pm 210$  mg/day/L. These values indicate controlled moisture transport capability and demonstrate the effectiveness of the interconnected nanofiber structure (Lopes et al., 2026).

Moisture ingress is recognized as one of the most significant degradation mechanisms in photovoltaic modules. Water penetration can induce corrosion, delamination, discoloration of encapsulants, adhesion loss, and electrical-performance deterioration. Consequently, materials capable of regulating vapor transport are highly desirable for photovoltaic durability enhancement.

The permeability values obtained in this study suggest that the carbon nanofiber layer may function as a moisture-buffering medium. Instead of allowing abrupt moisture accumulation, the porous network promotes gradual diffusion and redistribution of water vapor. Such behavior may reduce localized condensation formation and associated degradation phenomena.

The combination of mesoporosity, moderate surface area, and interconnected fiber architecture appears responsible for the observed permeability performance. These structural characteristics collectively support the proposed application of potato-derived carbon nanofibers as moisture-regulating supporting layers.

### Biodegradation Behavior

Biodegradation testing revealed mass losses ranging from 8–12% after 14 days. These results indicate partial environmental degradability while maintaining adequate structural stability during the testing period (Zhong et al., 2022).

The moderate biodegradation rate reflects the coexistence of stable aromatic carbon domains and residual biodegradable surface functionalities. Such behavior is advantageous from a sustainability perspective because the material retains operational integrity while reducing long-term environmental burden after disposal (Gamage et al., 2022).

Compared with many synthetic polymeric support materials, biomass-derived carbon nanofibers offer improved environmental compatibility and alignment with circular-economy principles.

### Proposed Moisture-Regulation Mechanism in Photovoltaic Modules

Based on the structural, morphological, and permeability results, a moisture-regulation mechanism is proposed. Water vapor entering the photovoltaic module initially interacts with oxygen-containing functional groups located on the carbon nanofiber surface. Subsequently, vapor molecules diffuse through interconnected mesoporous channels distributed throughout the nanofiber network (Muchuweni et al., 2022).

The moderate specific surface area provides temporary adsorption sites, while the interconnected pore structure facilitates gradual redistribution and release of moisture. This mechanism reduces localized moisture accumulation and minimizes the probability of condensation formation.

As a result, moisture-induced degradation phenomena such as corrosion, delamination, and encapsulant deterioration may be mitigated. Since moisture ingress is a major factor limiting photovoltaic durability, the incorporation of potato-derived carbon nanofibers could potentially contribute to improved long-term reliability, particularly in humid tropical environments (Yi et al., 2026).

### Comparative Analysis with Previously Reported Biomass-Derived Carbon Materials

To clarify the positioning and novelty of this study, a comparison with previously reported biomass-derived carbon materials is presented in Table 1.

Table 1 - Comparison of Biomass-Derived Carbon Materials for Energy Applications

Study	Biomass Source	Carbonization Temp (°C)	Activation	Morphology	Primary Application	Key Finding
Hoffman et al. (2020)	Potato waste	800–900	Chemical (KOH)	Porous carbon powder	Supercapacitor or electrode	High surface area for electrochemical storage
Din et al. (2023)	Waste potatoes	750	None	Carbon fiber electrode	Microbial fuel cell	Enhanced electricity generation
Zhang et al. (2023)	Agricultural biomass	800+	Chemical	Carbon nanofiber	Supercapacitor	High conductivity & capacitance
Straten et al. (2025)	Biomass residues	850	Chemical activation	Activated carbon	Energy storage	High porosity & surface area
This Study	Potato biomass	700	None (chemical-free)	Electrospun carbon nanofiber	PV supporting layer (moisture regulation)	Moderate permeability, structural compliance, sustainable processing

As shown in Table 1, most biomass-derived carbon materials reported in the literature focus on electrochemical energy storage applications and typically involve high-temperature

carbonization (>800 °C) combined with chemical activation to maximize surface area and conductivity (Dayana et al., 2025; Straten et al., 2025). In contrast, the present study adopts a moderate-temperature carbonization approach (700 °C) without chemical activation, prioritizing sustainability and reduced energy consumption (Dayana et al., 2024). Furthermore, while previous research emphasizes electrochemical performance, this work repositions potato-derived carbon nanofibers toward structural and moisture-regulating roles in photovoltaic modules. This application-oriented shift represents a distinct contribution to the field of sustainable carbon materials for renewable energy systems.

### Comparative Analysis with Previous Studies

Most previously reported biomass-derived carbon materials were developed primarily for supercapacitors, batteries, and electrochemical energy-storage systems. These studies frequently employed carbonization temperatures exceeding 800 °C together with chemical activation processes to maximize surface area and conductivity (Dayana et al., 2025).

In contrast, the present study demonstrates that moderate-temperature carbonization at 700 °C without chemical activation can produce carbon nanofibers exhibiting sufficient structural, surface, and transport properties for photovoltaic-support applications. While the measured surface area and conductivity are lower than those of activated supercapacitor carbons, the obtained values are appropriate for moisture-regulation functionality. The key novelty of this work therefore lies in shifting the application focus of biomass-derived carbon nanofibers from electrochemical energy storage toward photovoltaic durability enhancement. This multifunctional approach broadens the utilization potential of sustainable carbon materials within renewable-energy systems and provides a new pathway for biomass valorization (Dayana et al., 2024).

### 5. Conclusion

Potato-derived carbon nanofibers were successfully synthesized via moderate-temperature carbonization and electrospinning. Raman, BET, and conductivity measurements confirm formation of partially graphitized nanocarbon with moderate surface area and electrical performance. Controlled vapor permeability and structural integrity demonstrate feasibility as sustainable moisture-regulating supporting layers for photovoltaic modules. This work expands the functional positioning of biomass-derived carbon nanostructures within renewable energy material systems.

### Acknowledgement

The author would like to thank The DPPM Kemendiktisaintek for sponsorship and financial support with Grand number 203/P3MPI/3.1.1/VIII/2025. We also thank the Medan Area University, National Research and Innovation Agency (BRIN), Universitas Harapan, National Chung Hsing University for supporting this research.

### References

- Al-jamimi, H. A., Elgzoly, M. A. A., Al-azani, S., & Onaizi, S. A. (2026). Explainable metaheuristic-optimized XGBoost models for accurate prediction of CO<sub>2</sub> capture by graphene-based adsorbents. *JCIS Open*, 22(December 2025), 100179. <https://doi.org/10.1016/j.jciso.2026.100179>
- Alfei, S., & Zuccari, G. (2025). Carbon-Nanotube-Based nanocomposites in environmental remediation: an overview of typologies and applications and an analysis of their Paradoxical Double-Sided effects. *Journal of Xenobiotics*, 15(3), 76. <https://doi.org/10.3390/jox15030076>
- Ali, K. G., Taieh, N. K., & Khudhur, S. K. (2022). Investigation of Dry Tribo-Behavior of Aluminum Alloy AA6061/Al<sub>2</sub>O<sub>3</sub>/Graphite Composites Synthesized by Stir Casting Technique. *Revue des Composites et des Materiaux Avances*, 32(5), 253.
- Aseel, D. G., Abdelkhalek, A., Alotibi, F. O., Samy, M. A., Al-Askar, A. A., Arishi, A. A., & Hafez, E. E. (2022). Foliar application of nanoclay promotes potato (*Solanum tuberosum* L.) growth and induces systemic resistance against potato virus Y. *Viruses*, 14(10), 2151.

- Beissenov, R., Duisenbek, A., Beisenova, Y., Askaruly, K., Yeleuov, M., & Abdisattar, A. (2024). Activated biomass-derived 3-dimensional porous graphene-like carbon for high-performance energy storage electrode materials. *Diamond and Related Materials*, 149, 111588. <https://doi.org/10.1016/j.diamond.2024.111588>
- Dayana, I., Ramdan, D., Mungkin, M., Satria, H., Siregar, M. F., Rianna, M., Marbun, J., & Rahayu, S. U. (2024). Development of Potato Nano Carbon As Electrode for Supercapacitors Achieves Green-Sustainable Development Goals. *Journal of Applied Engineering and Technological Science*, 6(1), 508–518. <https://doi.org/10.37385/jaets.v6i1.5862>
- Dayana, I., Satria, H., Mungkin, M., Ramdan, D., Siregar, M. F., Junaidi, & Rahayu, S. U. (2025). Synthesis of Nano Carbon of Potatoes as Electrode for Environmentally Friendly Supercapacitor. *Journal of Advanced Research in Fluid Mechanics and Thermal Sciences*, 130(2), 11–24. <https://doi.org/10.37934/arfmts.130.2.1124>
- Fachredzy, A., Situmorang, C. R., Frida, E., Juwono, A. L., Tetuko, A. P., Fauzi, M., ... & Setiadi, E. A. (2026). THERMOPHYSICAL AND THERMAL CHARGING ENHANCEMENT OF PEG/Al<sub>2</sub>O<sub>3</sub> COMPOSITES FOR THERMAL ENERGY STORAGE (TES). *Indonesian Physical Review*, 9(1), 130-144.
- Guirguis, A., Yang, W., Conlan, X. A., Kong, L., Cahill, D. M., & Wang, Y. (2023). Boosting plant photosynthesis with carbon dots: a critical review of performance and prospects. *Small*, 19(43), 2300671. <https://doi.org/10.1002/smll.202300671>
- HEMMAMI, H., BEN AMOR, I., BEN AMOR, A., ZEGHOUD, S., AHMED, S., & ALHAMAD, A. A. (2024). Chitosan, Its Derivatives, Sources, Preparation Methods, and Applications: A Review. *Journal of the Turkish Chemical Society Section A: Chemistry*, 11(1), 341–364. <https://doi.org/10.18596/jotcsa.1336313>
- Hoffmann, V., Jung, D., Alhmidi, M. J., Mackle, L., & Kruse, A. (2020). Bio-based carbon materials from potato waste as electrode materials in supercapacitors. *Energies*, 13(9). <https://doi.org/10.3390/en13092406>
- Honcharuk, I., Tokarchuk, D., Gontaruk, Y., & Kolomiets, T. (2024). Production and Use of Biogas and Biomethane from Waste for Climate Neutrality and Development of Green Economy. *Journal of Ecological Engineering*, 25(2), 20–32. <https://doi.org/10.12911/22998993/175876>
- Idris, M. B., Mamba, B. B., & Xolile, F. (2026). RSC Advances Hierarchical pore engineering in waste-derived carbons for supercapacitors : bridging the performance gap from three-electrode evaluation to practical two-electrode devices. *RSC Advances*, 16, 29368–29398. <https://doi.org/10.1039/D6RA03341E>
- Jeong, B. J., Jiang, F., Sung, J. Y., Jung, S. P., Oh, D. W., Gnanamuthu, R. M., Lee, Y. S., & Lee, C. W. (2024). Biomass-derived carbon utilization for electrochemical energy enhancement in lithium-ion batteries. *Nanomaterials*, 14(12), 999. <https://doi.org/10.3390/nano14120999>
- Kuc, S. L., Kądziela, A., Staniszevska, M., Janczak, D., Jakubowska, M., Bednarczyk, E., Murawski, T., Piłczyńska, K., & Tryznowska, Z. Ż. (2024). Sustainable , cytocompatible and flexible electronics on potato starch - based films. *Scientific Reports*, 1–12. <https://doi.org/10.1038/s41598-024-69478-1>
- Kumar, P., Dua, S., Kaur, R., Kumar, M., & Bhatt, G. (2022). A review on advancements in carbon quantum dots and their application in photovoltaics. *RSC Advances*, 12(8), 4714–4759. <https://doi.org/10.1039/D1RA08452F>
- Lopes, I. S., Kennedy, J., Medeiros, L. S. De, & Courrol, L. C. (2026). GABA-mediated and light-assisted synthesis of green GABA-SeNPs for microbial control and plant nano-primer. *JCIS Open*, 22(September 2025), 100178. <https://doi.org/10.1016/j.jciso.2026.100178>
- Medina-Jaramillo, C., Coelho-Leandro, G., Ayala-Valencia, G., & López-Córdoba, A. (2025). Starch-based biocomposites reinforced with cellulose nanofibers from potato peel byproducts. *Scientific Reports*, 15(1), 38412. <https://doi.org/10.1038/s41598-025-23067-2>
- Muchuweni, E., Mombeshora, E. T., Martincigh, B. S., & Nyamori, V. O. (2022). *Recent Applications of Carbon Nanotubes in Organic Solar Cells*. 9(January), 1–16. <https://doi.org/10.3389/fchem.2021.733552>

- Gamage, A., Thiviya, P., Mani, S., Ponnusamy, P. G., Manamperi, A., Evon, P., Merah, O., & Madhujith, T. (2022). Environmental properties and applications of biodegradable starch-based nanocomposites. *Polymers*, *14*(21), 4578. <https://doi.org/10.3390/polym14214578>
- Petrichenko, S., Malushevskaya, A., Ivanov, A., Mitryasova, O., & Salamon, I. (2024). Improving the Efficiency of Water Purification from Heavy Metals using the Electric Spark Method. *Journal of Ecological Engineering*, *25*(8), 1–9. <https://doi.org/10.12911/22998993/189230>
- Phuong, T., Ngoc, T., Huynh, D., Nguyen, M., Thi, T., Ho, A., Truong, S., & Thanh, V. T. (2025). Graphitic porous carbon fabricated from waste coffee grounds for supercapacitors. *Next Materials*, *9*(August), 101021. <https://doi.org/10.1016/j.nxmte.2025.101021>
- Satria, H., Maizana, D., & Dayana, I. (2025). Optimization of parabolic photovoltaic and solar thermal tracker model systems using heat transfer fluid. *Bulletin of Electrical Engineering and Informatics*, *14*(3), 1656–1666. <https://doi.org/10.11591/eei.v14i3.8988>
- Singh, A., Kafle, S. R., Sharma, M., & Kim, B. S. (2023). Comprehensive review on multifaceted carbon dot nanocatalysts: Sources and energy applications. *Catalysts*, *13*(11), 1446. <https://doi.org/10.3390/catal13111446>
- Singh, M., & Biswas, A. (2025). Impact of quenching on the microstructure and mechanical properties of hybrid aluminum matrix composites (Al7075/SiC/TiB<sub>2</sub>). *Proceedings of the Institution of Mechanical Engineers, Part E: Journal of Process Mechanical Engineering*, 09544089251338933. <https://doi.org/10.1177/09544089251338933>
- Sohail, A. (2025). Next Nanotechnology Progress in nanomaterials : Synthesis , characterization , and applications. *Next Nanotechnology*, *8*(September), 100263. <https://doi.org/10.1016/j.nxnano.2025.100263>
- Straten, J. W., Alhniidi, M. J., Alchoumari, G., Sangam, K., & Kruse, A. (2025). B,N-doped activated carbon-based electrodes from potato peels for energy storage applications. *ChemistryOpen*, *14*(3), e202400527. <https://doi.org/10.1002/open.202400527>
- Supha, C., Ahmed, R., Wattayagorn, V., Thongmee, S., & Chumnanpuen, P. (2026). Synthesis and characterization of Mg-doped CuO nanoparticles and their enhanced anticancer efficacy against HepG2 liver cancer cells. *International Journal of Molecular Sciences*, *27*(4), 1647. <https://doi.org/10.3390/ijms27041647>
- William, J. J., Balakrishnan, S., Murugesan, M., Gopalan, M., Britten, A. J., & Mkandawire, M. (2022). Mesoporous  $\beta$ -Ag<sub>2</sub>MoO<sub>4</sub> nanopotatoes as supercapacitor electrodes. *Materials Advances*. <https://doi.org/10.1039/d2ma00708h>
- Xi, M., Wan, R., Luo, W., He, Y., Feng, X., Wang, T., ... & Luo, Z. (2026). Graphene Oxide-based Biomaterials in Sports Medicine. *BIO Integration*, *7*(1), 989. <https://doi.org/10.15212/bioi-2025-0172>
- Yeamsuksawat, T., Zhu, L., Kasuga, T., Nogi, M., & Koga, H. (2023). Chitin-Derived Nitrogen-Doped Carbon nanopaper with subwavelength nanoporous structures for solar thermal heating. *Nanomaterials*, *13*(9), 1480. <https://doi.org/10.3390/nano13091480>
- Yi, B., Sun, Z., Deng, J., Lim, J. Y., Senadheera, S., Yuan, Q., ... & Ok, Y. S. (2026). Sustainably graphitizing biomass into advanced carbon materials for energy and environmental applications. *Sustainable Carbon Materials*, *2*(1), e003. <https://doi.org/10.48130/scm-0026-0003>
- Zhang, M., Li, P., & Wu, D. (2023). Editorial for special issue: “Synthesis and application of biomass-derived carbon-based nanomaterial”. *Nanomaterials*, *13*(13), 2020. <https://doi.org/10.3390/nano13132020>
- Zhong, M., Zhang, M., & Li, X. (2022). Carbon nanomaterials and their composites for supercapacitors. *Carbon Energy*, December 2021, 950–985. <https://doi.org/10.1002/cey2.219>